

VECTOR

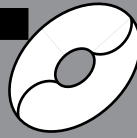

*Installation and
Operation Manual
V2008-991-2400A1*

PERISTALTIC PUMPS

***Vector 2000 Series
Models: 2008, 2009, 2010***



W0381

Model 2008 Shown

Vector 2008, 2009, 2010 Contents

Contents

Caution	2
Component Identification	2
How it Works	3
Inspection	3
Installation Planning	3
Site Plumbing	3
Pump Set-Up	4
Hose Compression Adjustment	4
Before System Start-Up	4
System Start-Up	4
Preventive Maintenance	5
Disassembly and Reassembly	6
Hose Removal	6
Hose Replacement	6
Troubleshooting	7
Storage	7
Spare Parts	7
Parts	
Exploded View	8
Model 2008 Part Numbers	9
Model 2009 Part Numbers	9
Model 2010 Part Numbers	10
Gearmotor/Gearbox Part Numbers	11
Warranty	12



CAUTION

Important Precautions

- To avoid personal injury or pump damage, follow all instructions and safety precautions carefully.
- Don't exceed the manufacturer's recommended RPM or pressure limits.
- Follow all codes and hydraulic recommendations on installation and operation of the pumping system.
- To prevent vibration, mount the pump and motor securely to a rigid, level base.
- For safety and easier servicing, provide adequate work space around the pump. Allow space to remove the front cover, hose clamps, hose, and drive unit.

W0387

Component Identification

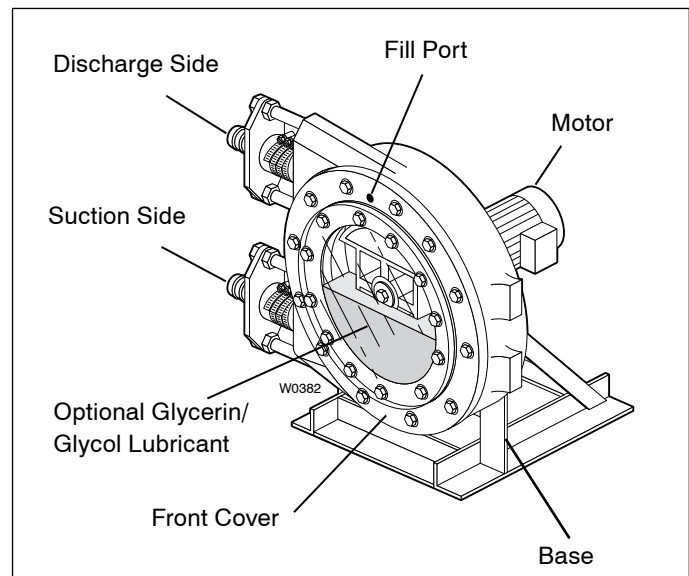

Vector 2008, 2009, 2010 Installation

How it Works

Two roller assemblies, mounted on a rotor, alternately compress a thick-walled hose in a patented concentric guide. As the rollers rotate, they push the liquid in the hose from the suction side of the pump to the discharge side. Also after a roller passes the hose opens which creates a vacuum on the suction side which results in even continuous pumping.

Inspection

The pump must be checked upon receipt for any possible damage or incomplete shipment. Notify Wanner Engineering of any discrepancies immediately.

Check all boxes or packages containing spare parts or accessories packed with the pump.

Installation Planning

Location

1. Locate the pump near the liquid source, so that the suction line is short and direct.
2. When practical, locate the pump above the level of the liquid; if the hose fails, the pumpage drains back into the tank.
3. **Allow space to remove the front cover, hose, and drive unit.**

Foundation

The foundation should be sufficiently rigid and substantial to absorb any vibration, and to permanently support the base plate at all points. A concrete foundation, poured on a solid footing of adequate thickness to support the pumping unit provides the most satisfactory foundation.

The base plate should be installed in a level position. The size and location of the base mounting holes are shown on the pump specification sheets. Use the dimensions provided in the pump specification data sheets for general piping.

Note: For a detailed description of proper procedures for grouting base plates, refer to the Hydraulic Institute Standards.

Site Plumbing

ATTENTION! Do not 'hard pipe' pump to process plumbing. See Figure 1 for correct installation.

Inlet Piping

- Size the inlet line one or two sizes larger than the pump suction opening.
- Suction lines should be as short and direct as possible.
- See Figure 1. Install 6 to 8 feet of reinforced flexible hose between pump and rigid piping to absorb vibration, expansion and contraction, and to make maintenance easier.
Note: The flexible hose reinforcement must be capable of withstanding a vacuum. This avoids hose collapse which will restrict flow.
- Install an inlet pressure/vacuum gauge on the inlet side of the pump.
- To reduce turbulence and resistance, do not use 90° elbows. If turns are necessary in the suction line use 45° elbows or long sweeping elbows when required.
- Install piping supports where necessary to relieve strain on the inlet line and to minimize vibration.
- In some cases, a pulsation dampener may be required to decrease acceleration head and pulsations. Mount dampener within ten pipe diameters of the pump suction connection. The closer the better.

Discharge Piping

- See Figure 1. Install 6 to 8 feet of reinforced flexible hose (one size larger than pump connection) between pump and rigid piping. This will absorb vibration, provide for expansion and contraction. It also creates a reservoir and eases the replacement of the hose.
- Size the rigid discharge line to be at least the size of the pump inlet connection.
- Install piping supports where necessary to relieve strain on discharge piping and to minimize vibration.
- Install a pressure gauge in the discharge piping.
- In some cases, a pulsation dampener may be required to decrease pulsations. Mount dampener within ten pipe diameters of the pump discharge connection. The closer the better.

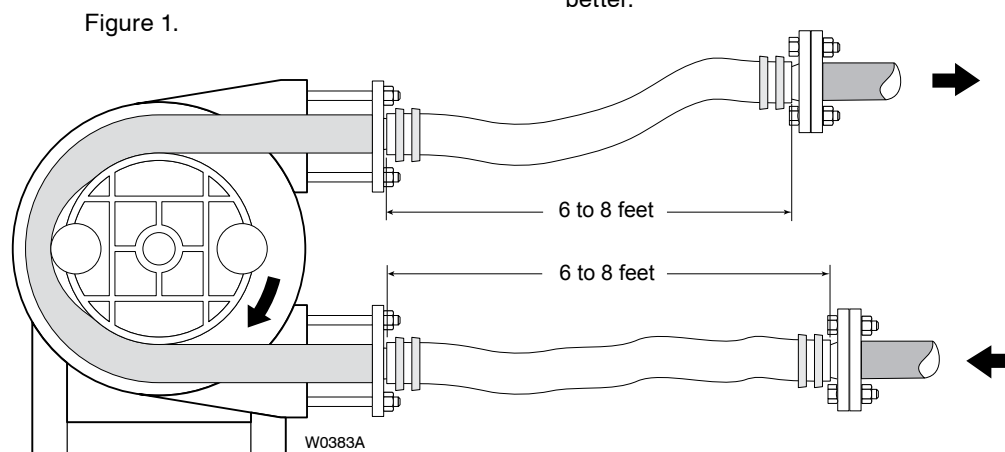

Vector 2008, 2009, 2010 Installation

Pump Set-Up

Note: Refer to the Parts List Illustration. The numbers in parentheses () are the Reference Numbers used in the Parts List.

1. Make sure pump is completely assembled, and that all fasteners, hose clamps, etc. are properly tightened.
Note: The chamber should not be filled with lubricant at this time.
2. Remove transparent inspection window front cover (4) and gasket (3) so that rotor (9) is accessible. There should be light film of **non-petroleum** silicone on hose (18) in area of roller assembly (10) contact. If not, apply.
3. Connect motor per motor manufacturer's instructions.
4. Run pump and check proper rotor rotation. If rotor rotation is wrong, check motor terminals for proper connection.
5. Pump is now ready for hose compression adjustment.

Hose Compression Adjustment

Roller pressure is not set at the factory because it must be adjusted specifically to the application requirements. For optimum hose life, set just enough compression to accomplish desired pump operation, vacuum and discharge pressure. The more the hose is compressed the shorter the hose life.

Note: The pump does not need to be filled with lubricant to adjust hose compression. However, be sure that non-petroleum silicone has been applied on the hose in the area of roller contact. This will protect the hose during compression adjustment.

1. Remove window front cover (4) and gasket (3) as in Pump Set-Up above.
2. Start pump.
3. Place hand over suction port and check whether roller is compressing hose (10) enough to create vacuum.
4. Gradually add shims (11) to each roller assembly (10) and continue testing until vacuum exists. Maximize hose life by installing only enough shims for pump application.
5. Make sure each roller assembly has same number of shims.

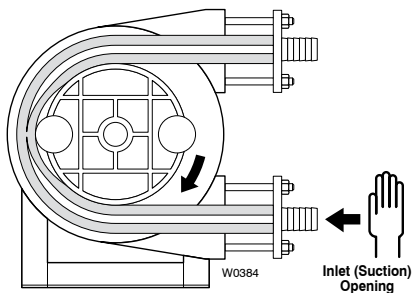

Note: These models can either be lubricated by a non-petroleum grease that is applied to the portion of hose that makes contact with the rollers or they can be lubricated by partially filling the case with a glycerin/glycol mixture.

6. If silicone grease is used, lubricate hose at this time, If glycerin/glycol is used proceed to next step.
7. Install front cover (4) and gasket (3).
8. Fill pump with lubricant to level just below pump shaft (Lubricant can be filtered to 100 microns and used again). Glycerin/glycol as follows: Model 2008 - 4 US gallons; Model 2009 - 8.5 US gallons; Model 2010 - 15.8 US gallons.

Before System Start-Up

Before you pump fluid through the system, be sure that:

1. All connections are tightly secured.
2. See Hose Identification Table. Hose material is compatible with fluid being pumped, and hose design matches duty cycle and discharge pressures.

Hose Identification		
Extruded	Code	Description
Hypalon	HE	Black color, shinny smooth surface
Neoprene	PE	Flat black color, rough surface, rubber smell
Varprene	VE	Cream color, smooth surface
Silicone	SE	Rust color, smooth surface
Pharmed®	FE	Cream color, Pharmed® name on hose
Fiber Braided		
Hypalon	HF	Black color, yellow stripe, double braided
EPDM	EF	Black color, white stripe, double braided
Natural Rubber	NF	Black color, green stripe, double braided (standard duty)
Natural Rubber	MF	Black color, no stripes, thick double braids (heavy duty)
Nitrile Rubber	BF	Black color, white inner hose
Nitrile Rubber - Oil Rated	OF	Black color, HBRF-HY-K stamped on hose (heavy duty)

3. See Material Operating Temperatures Table. Temperature of fluid pumped is within operating temperature range of hose material installed in pump. Hose material can be identified by 5th and 6th digit of pump model number. E.g. 2008-NF-BB-D2, where 'NF' designates natural rubber.

CAUTION: Contact factory when pumping a fluid that is within 15° F of the maximum hose temperature. Take safety precautions to insure hot pumpage does not harm operators if a hose leaks.

Material Operating Temperatures	
Material	Operating Temperatures
EPDM	32 to 185° F
Hypalon	32 to 180° F
Neoprene	50 to 130° F
Silicone	14 to 185° F
Varprene	14 to 185° F
Natural Rubber	14 to 185° F
Nitrile Rubber	23 to 160° F
Pharmed®	32 to 180° F

System Start-Up

1. Connect system piping to inlet and discharge connectors.
2. Open all shut-off valves to system.

Vector 2008, 2009, 2010 Maintenance

System Start-Up (Cont'd)

3. Start pump.
4. Monitor pump for any signs of leakage.
5. Monitor pump performance. In the event flow and pressure are not satisfactory, repeat hose compression adjustment procedures above. This will require lubricant in pump case to be drained by removing drain plug (12). Pumpage fluid will have to be drained as well. Refer to Disassembly and Reassembly Section for cautions on handling.

Preventive Maintenance

A preventive maintenance program can increase the pump life. THE PROCEDURES DESCRIBED IN THIS MANUAL DO NOT REPLACE THE EXPERIENCE AND THE KNOWLEDGE OF OUR TECHNICAL STAFF. Please feel free to contact Wanner Engineering if you need assistance.

Routine Inspection

1. Verify the pump is pumping.
2. Check that lubricant level is just below shaft.
Note: When glycerine/glycol is used or if silicone grease lubricant is used, the hose should not run dry in the area where the rollers make contact with the hose.
3. Make sure noise and vibration is within normal range.

Monthly Inspection

1. Check that all fasteners are properly tightened.
2. In addition to routine inspection, check that base plate mounting bolts are tight and not corroded.
3. Check flow rate and pressure. If operating conditions have not changed and the pumps performance does not meet requirements, inspect parts for wear.
4. Verify there are no abnormal leakages of lubricant or pumpage.

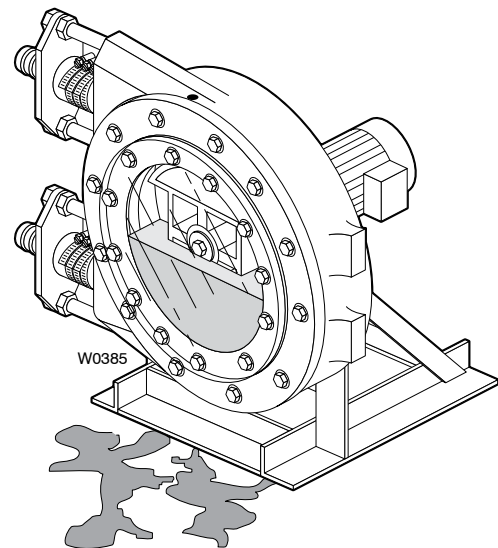

Vector 2008, 2009, 2010 Disassembly

Disassembly and Reassembly

Before disassembling the pump for repair, contact Wanner Engineering to make sure that required original spare parts are available.

CAUTION: The pump may have handled dangerous or toxic liquids; it is therefore necessary to protect against contact with skin, eyes, etc.

Liquid must be recovered and eliminated according to all applicable environmental laws.

If a pump has been used to pump corrosive or toxic liquids, it must be thoroughly drained and cleaned before returning it to the manufacturer for reconditioning.

Hose Removal

1. Turn off and lock-out power to motor.
2. Disconnect pump from the piping system.
3. Drain lubricant, if used, from pump case by removing drain plug (12), (Lubricant can be filtered to 100 microns and used again).
4. Loosen hose clamps (27) and tie rod nuts (26) from inlet and discharge.
5. Remove hose connectors (25) and internal sleeve (23) from inlet and discharge.
6. Remove flange (20) and flange gasket (Item 19) from the inlet and discharge.
7. Remove front cover (4).
8. Position rotor (9) so one roller assembly (10) is not compressing the hose. Then remove roller assembly and shims.
9. Turn rotor (9) 180° to position second roller assembly in idle position.
10. Remove hose.
11. Clean inside of case of debris and make sure rollers are in good working condition.

Hose Replacement

1. Turn off and lock-out power to motor.
2. Spread non-petroleum silicone on idle roller assembly (10) in pump.
3. Check that you have correct length of hose.
Model 2008: 1850 mm or 72.83 inches
Model 2009: 2400 mm or 94.49 inches
Model 2010: 3250 mm or 127.95 inches
4. Install hose and make sure length of hose extending from inlet and discharge are the same.
NOTE: It is important to have 2-3 mm gap between hose and the inside of the pump casing.
5. Install hose flanges (20) and flange gaskets (19).
6. Install internal sleeves (22) and external sleeves (23).
7. Install clamps, not tightened yet.
8. Install connectors (25) and tighten hose clamps.
9. Rotate rotor 180° and install second roller assembly and same number of shims as removed if there were any.

10. Spread non-petroleum silicone on idle roller assembly.
11. Complete assembly.
12. Check hose compression. Compression may vary with new hose due to variations in hose diameter. See paragraphs on Hose Compression Adjustment and Start-Up in Installation Section.

Vector 2008, 2009, 2010 Troubleshooting

Troubleshooting

1) Pump Temperature

Pump temperature can increase because of:

- Unsuitable lubricant
- Excessive temperature of the product
- Worn out bearings
- Roller overshimming
- Excessive pump speed

2) Low Flow or Low Pressure

The capacity or the pump discharge pressure can be lower than nominal because of:

- Closed valves on suction or discharge
- Wrong roller pressure adjustment
- Hose rupture (in which the pump casing gets filled with the pumpage)
- Partially blocked suction line or not enough product in the suction tank
- Pump has not been properly selected in terms of speed, excessive suction and discharge piping, excessive product viscosity, etc.
- Air in the suction line

3) Vibration and Water Hammering of Pump and Piping

The Vector pump has a pulsating flow that may cause vibrations on the pump and on the piping whenever one of the following circumstances occurs:

- Suction and discharge piping is not anchored
- Excessive pump rotating speed in conjunction with a long suction piping and with a high specific gravity
- Suction and discharge piping is too small

4) Short Hose Life

Hose life is generally determined by the following parameters:

- Chemical attack; unsuitable material for the pumped liquid
- High pump speed; a low speed increases hose life
- Discharge pressure and product temperature; an excessive pressure and/or a high product temperature create higher stress to the pump and on the hose reinforcement, thus reducing its life
- Excessive shimming of the pressure rollers (10)

5) Friction Pulling of the Hose within the Pump Casing

The hose can be pulled inside the pump casing because of:

- Insufficient or lacking lubricant
- Excessive inlet pressure
- Non-compressible particles or objects within the hose that do not allow the liquid to flow. Thus, the hose cannot be compressed and, consequently, can be pushed within the pump casing
- No gap between hose and casing

Storage

Store the pump in a dry and clean environment, with no vibrations.

Install protective plugs into/over the pump connections in order to avoid dirt or foreign material from entering the pump casing.

In case the pump is going to be stored for a long period, idle one of the pressure rollers to avoid leaving any marks and potential damage to the hose, possibly causing problems when starting the pump. (Do not store with hose in compression.)

Spare Parts

For correct spare parts, please contact Wanner Engineering with:

- Pump model
- Serial number

This information is indicated on the pump name plate placed on the pump.

Recommended Spare Parts

Item	Description	Quantity/Pump
3	Gasket, Front Window	1
6	O-ring, Front cover	1
10	Roller/Bearing Holder Assembly	2
18	Hose	1
19	Gasket, Flange	2
*	Lubricants (See page 11)	

Vector 2008, 2009, 2010 Parts

Exploded View

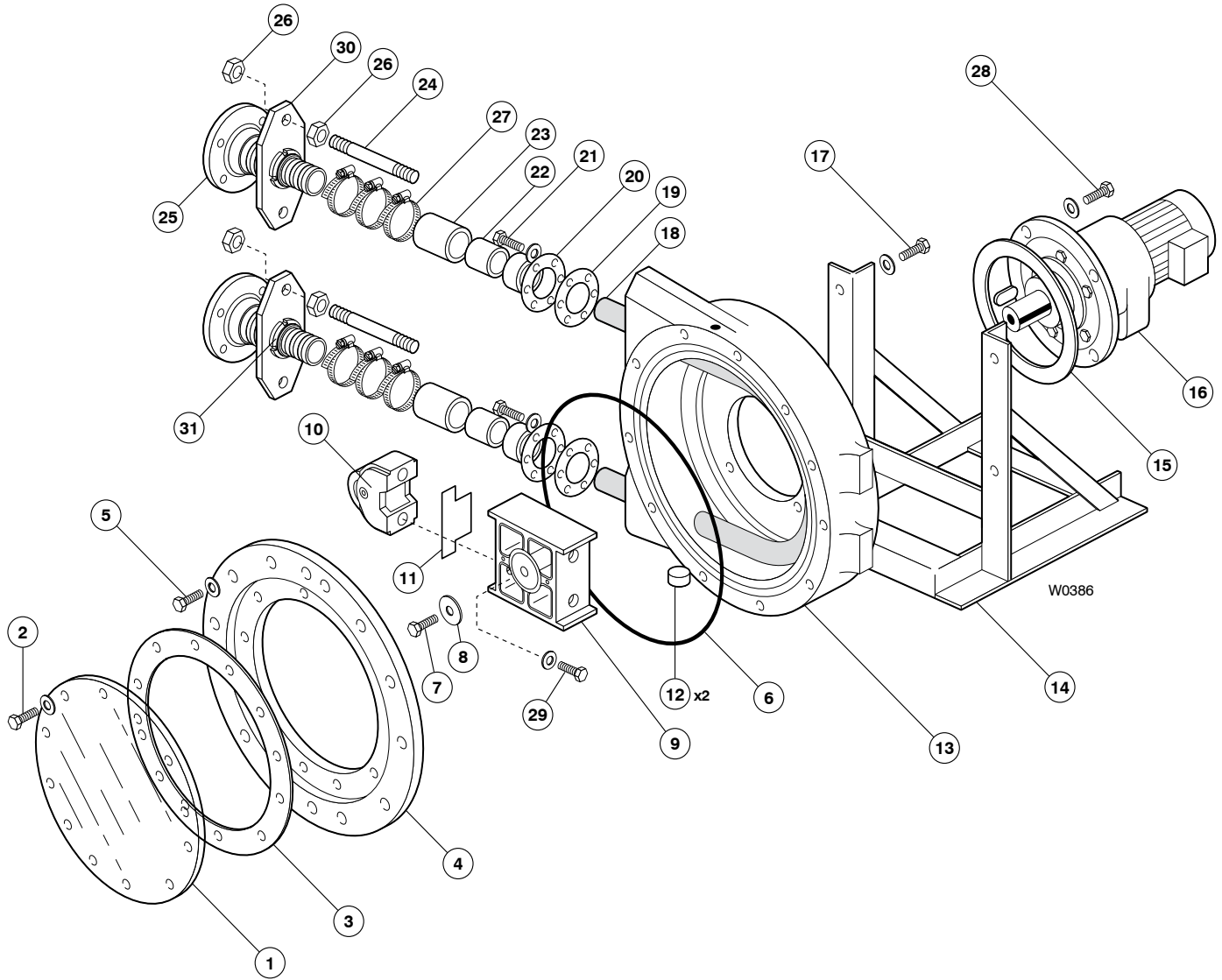

Vector 2008, 2009 Parts

Model 2008 Part Numbers

Ref. No.	Part Number	Description	Quantity/ Pump
1	2008-003-1001	Window, Front	1
2	2008-003-1003	Cap Screw, Front Window	12
3	2008-002-1002	Gasket, Front Window	1
4	2008-002-1001	Cover, Front.....	1
5	2008-002-1003	Cap Screw, Front Cover.....	12
6	2008-001-1012	O-ring, Front Cover	1
7	2008-004-1005	Bolt, Rotor	1
8	2008-004-1003	Washer, Rotor	1
9	2008-004-1001	Rotor.....	1
10	2008-104-1001	Roller/Bearing Holder Assembly.....	2
11	2008-099-1001	Shim	6
12	2008-001-1003	Plug, case drain	2
13	2008-001-1001	Casing	1
14	2008-017-1001	Base	1
15	2008-017-1005	Gear motor gasket	1
16	See page 11	Gearbox and Gearmotor	1
17	2008-017-1003	Cap Screw, Mounting.....	4
18	2008-108-2326	Hose, Hypalon, Fiber Braided	1
	2008-108-2349	Hose, Natural Rubber, FB, Heavy Duty	1
	2008-108-2329	Hose, Natural Rubber, FB, Std Duty	1
	2008-108-2323	Hose, EPDM, FB, Std Duty	1
	2008-108-2332	Hose, Oil-rated Nitrile, FB, Heavy Duty	1
19	2008-019-1003	Gasket, Flange.....	2
20	2008-019-1001	Flange	2
21	2008-019-1005	Cap Screw, Flange	8
22	2008-020-1003	Sleeve, Internal	2
23	2008-020-1005	Sleeve, External.....	2
24	2008-018-1001	Tie Rod.....	4
25	2008-016-1105	Connector, 316 SST, 3" 150 lb Flange	2
	2008-016-1112	Connector, 316 SST, 3" Male NPT	2
	2008-016-1107	Connector, Carbon Steel, 3" Male NPT	2
	2008-016-1108	Connector, Nylon, 3" Male NPT	2
	2008-016-1109	Connector, Polypropylene, 3" Male NPT.....	2
26	2008-018-1003	Nut, Tie Rod	8
27	2008-020-1001	Clamp, Hose Connection.....	6
28	2008-017-1007	Bolt, Gear motor.....	4
29	2008-104-1003	Cap Screw, Roller Holder	4
30	2008-116-1100	Plate, Connector	2
31	2008-116-1101	Nut, Connector	2

Model 2009 Part Numbers

Ref. No.	Part Number	Description	Quantity/ Pump
1	2008-003-1001	Window, Front	1
2	2008-003-1003	Cap Screw, Front Window	12
3	2008-002-1002	Gasket, Front Window	1
4	2009-002-1001	Cover, Front.....	1
5	2009-002-1003	Cap Screw, Front Cover.....	12
6	2009-001-1012	O-ring, Front Cover	1
7	2009-004-1005	Bolt, Rotor	1
8	2009-004-1003	Washer, Rotor	1
9	2009-004-1001	Rotor.....	1
10	2009-104-1001	Roller/Bearing Holder Assembly.....	2
11	2009-099-1001	Shim	6
12	2009-001-1003	Plug, case drain	2
13	2009-001-1001	Casing	1
14	2009-017-1001	Base	1
15	2009-017-1005	Gear motor gasket	1
16	See page 11	Gearbox and Gearmotor	1
17	2009-017-1003	Cap Screw, Mounting.....	4
18	2009-108-2326	Hose, Hypalon, Fiber Braided.....	1
	2009-108-2349	Hose, Natural Rubber, FB, Heavy Duty	1
	2009-108-2329	Hose, Natural Rubber, FB, Std Duty	1
	2009-108-2323	Hose, EPDM, FB, Std Duty	1
	2008-108-2332	Hose, Oil-rated Nitrile, FB, Heavy Duty	1
19	2009-019-1003	Gasket, Flange.....	2
20	2009-019-1001	Flange	2
21	2009-019-1005	Cap Screw, Flange	8
22	2009-020-1003	Sleeve, Internal	2
23	2009-020-1005	Sleeve, External.....	2
24	2009-018-1001	Tie Rod.....	4
25	2009-016-1105	Connector, 316 SST, 4" 150 lb Flange	2
	2009-016-1112	Connector, 316 SST, 4" Male NPT	2
	2009-016-1107	Connector, Carbon Steel, 4" Male NPT	2
	2009-016-1108	Connector, Nylon, 4" Male NPT	2
26	2009-018-1003	Nut, Tie Rod	8
27	2009-020-1001	Clamp, Hose Connection.....	6
28	2009-017-1007	Bolt, Gear motor.....	4
29	2009-104-1003	Cap Screw, Roller Holder	4
30	2009-116-1100	Plate, Connector	2
31	2009-116-1101	Nut, Connector	3

Vector 2010 Parts

Model 2010 Part Numbers

Ref. No.	Part Number	Description	Quantity/ Pump
1	2010-003-1001	Window, Front	1
2	2010-024-1001	Cap Screw, Front Window	8
3	2010-002-1002	Gasket, Front Window	1
4	2010-002-1001	Cover, Front.....	1
5	2010-021-1001	Cap Screw, Front Cover.....	8
6	2010-001-1012	O-ring, Front Cover	1
8	2010-009-1002	Washer, Drive bolt.....	4
	2010-020-1001	Washer, Rotor	1
	2010-022-1001	Bolt, Rotor	1
9	2010-004-1001	Rotor.....	1
10	2010-105-1001	Roller/Bearing Holder Assembly.....	2
11	2010-099-1001	Shim (set of six)	1
12	2010-001-1003	Plug, case drain	2
13	2010-001-1001	Casing	1
14	2010-006-1001	Base	1
15	2010-017-1005	Gear motor gasket	1
16	See page 11	Gearbox and Gearmotor	1
17	2010-007-1001	Cap Screw, Mounting.....	4
18	2010-108-2326	Hose, Natural Rubber, Steel Braided.....	1
	2010-108-2320	Hose, Nitrile Rubber, Steel Braided.....	1
	2010-108-2349	Hose, Hypalon, Steel Braided.....	1
	2010-108-2323	Hose, EPDM Steel Braided	1
19	2010-019-1003	Gasket, Flange.....	2
20	2010-019-1001	Flange	2
21	2010-019-1005	Cap Screw, Flange	8
22	2010-020-1003	Sleeve, Internal	2
23	2010-020-1005	Sleeve, External.....	2
24	2010-026-1001	Tie Rod.....	4
25	2010-016-1106	Connector, Carbon Steel, 6" ANSI Flange .2	
	2010-016-1210	Connector, PVC, 5" ANSI Flange(176 F)	2
	2010-016-1118	Connector, Nylon, 5" ANSI Flange(248 F) .2	
26	2010-010-1001	Nut, Tie Rod	8
27	2010-023-1001	Clamp, Hose Connection.....	8
28	2010-117-1007	Bolt, Gear motor.....	4
29	2010-009-1001	Cap Screw, Roller Holder	4
30	2010-017-1001	Plate, Connector	2
31	2010-018-1001	Nut, Connector	2

Vector 2008, 2009, 2010 Parts

Gearmotor Part Numbers (including gearbox)

Part Number	Description
Model 2008	
GM83RF97300	Gearmotor, B2, 83:1 Ratio, 3 BHP
GM60RF97500	Gearmotor, D2, 60:1 Ratio, 5 BHP
GM48RF97500	Gearmotor, F2, 48:1 Ratio, 5 BHP
GM42RF97500	Gearmotor, H2, 42:1 Ratio, 5 BHP
GM37RF97500	Gearmotor, J2, 37:1 Ratio, 5 BHP
GM27RF97750	Gearmotor, L2, 27:1 Ratio, 7.5 BHP
Model 2009	
GM79RF107500	Gearmotor, B2, 79:1 Ratio, 5 BHP
GM60RF107750	Gearmotor, D2, 60:1 Ratio, 7.5 BHP
GM489RF107750	Gearmotor, F2, 48:1 Ratio, 7.5 BHP
GM40RF1071000	Gearmotor, H2, 40:1 Ratio, 10 BHP
GM35RF1071000	Gearmotor, J2, 35:1 Ratio, 10 BHP
GM28RF1071500	Gearmotor, L2, 28:1 Ratio, 15 BHP
Model 2010	
GM174RF1371000	Gearmotor, B2, 174:1 Ratio, 10 BHP
GM114RF1371000	Gearmotor, F2, 114:1 Ratio, 10 BHP
GM89RF1371500	Gearmotor, G2, 89:1 Ratio, 15 BHP
GM59RF1371500	Gearmotor, M2, 59:1 Ratio, 15 BHP
GM44RF1372000	Gearmotor, T2, 44:1 Ratio, 20 BHP

Lubricants

The following are hose lubricant options and lubricant quantities for use with the Vector pumps:

Part Number	Description
2000-115-3400	Silicone Grease, 5.3 oz tube
2000-115-3401	Silicone Grease, 14.1 oz tube
3000-115-3406	Glycerine/Glycol Lubricant, 6 liters
3000-115-3408	Glycerine/Glycol Lubricant, 1 quart
3000-115-3404	Glycerine/Glycol Lubricant, 1 gallon

Gearbox Part Numbers (less motor)

Part Number	Description
Model 2008 Gearbox for NEMA 182TC Frame Size Motor:	
2008-GB-83-182	83:1 ratio
Model 2008 Gearbox for NEMA 184TC Frame Size Motor:	
2008-GB-60-184	60:1 ratio
2008-GB-48-184	48:1 ratio
2008-GB-42-184	42:1 ratio
2008-GB-37-184	37:1 ratio
2008-GB-27-184	27:1 ratio
Model 2009 Gearbox for NEMA 184TC Frame Size Motor:	
2009-GB-79-184	79:1 ratio
Model 2009 Gearbox for NEMA 213TC Frame Size Motor:	
2009-GB-60-213	60:1 ratio
2009-GB-48-213	48:1 ratio
Model 2009 Gearbox for NEMA 215TC Frame Size Motor:	
2009-GB-40-215	40:1 ratio
2009-GB-35-215	35:1 ratio
Model 2009 Gearbox for NEMA 254TC Frame Size Motor:	
2009-GB-28-254	28:1 ratio
Model 2010 Gearbox for NEMA 215TC Frame Size Motor:	
2010-GB-174-215	174:1 ratio
2010-GB-114-215	114:1 ratio
Model 2010 Gearbox for NEMA 254TC Frame Size Motor	
2010-GB-89-254	9:1 ratio
2010-GB-59-254	59:1 ratio
Model 2010 Gearbox for NEMA 256TC Frame Size Motor:	
2010-GB-44-256	44:1 ratio

Vector 2008, 2009, 2010 Warranty

Limited Warranty

Wanner Engineering, Inc. extends to the original purchaser of equipment manufactured by it and bearing its name, a limited one-year warranty from the date of purchase against defects in material or workmanship, provided that the equipment is installed and operated in accordance with the recommendations and instructions of Wanner Engineering, Inc. Wanner Engineering, Inc. will repair or replace, at its option, defective parts without charge if such parts are returned with transportation charges prepaid to Wanner Engineering, Inc., 1204 Chestnut Avenue, Minneapolis, Minnesota 55403.

This warranty does not cover:

1. The electric motors (if any), which are covered by the separate warranties of the manufacturers of these components.
2. Normal wear and/or damage caused by or related to abrasion, corrosion, abuse, negligence, accident, faulty installation or tampering in a manner which impairs normal operation.
3. Transportation costs.

This limited warranty is exclusive, and is in lieu of any other warranties (express or implied) including warranty of merchantability or warranty of fitness for a particular purpose and of any non contractual liabilities including product liabilities based on negligence or strict liability. Every form of liability for direct, special, incidental or consequential damages or loss is expressly excluded and denied.